

Heidra 250™ Hydraulic Submersible Pumps

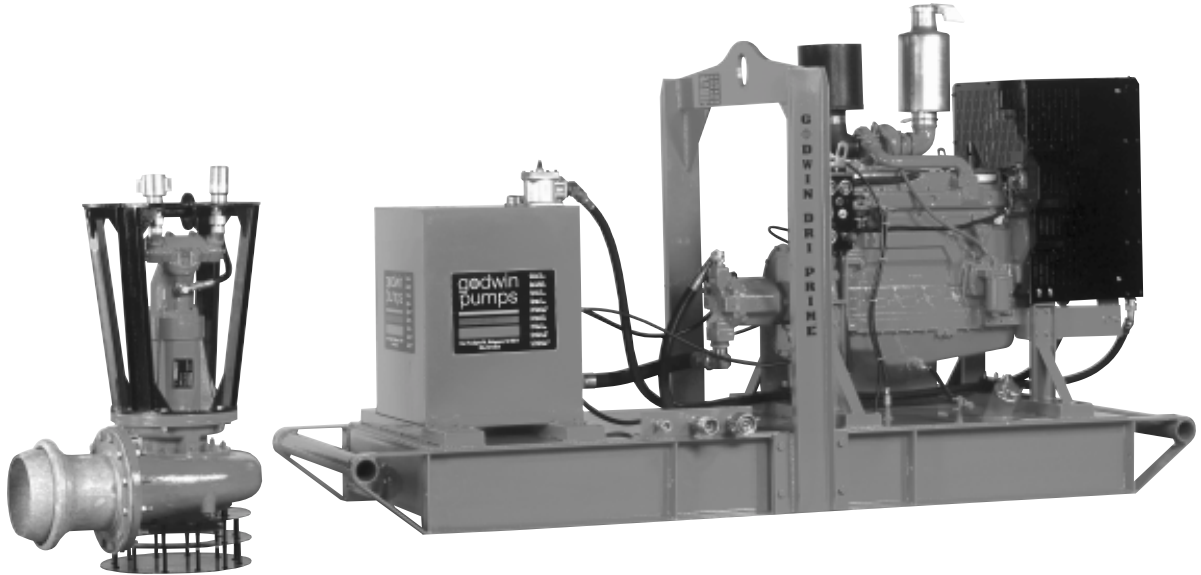

The Heidra 250 Hydraulic Submersible Pump is a self-contained, diesel powered 10" pump available for heavy duty municipal and industrial dewatering and solids handling pumping applications. The Heidra 250 offers flow rates up to 3500 gpm with up to 185' of total dynamic head and solids handling capability of 3-1/8" in diameter. The unit consists of a sturdy cast iron submersible pumpend and hydraulic power pack mounted on a rugged steel skid. A variable displacement hydraulic piston pump on the power pack delivers hydraulic fluid to a fixed displacement piston motor that drives the pumpend's shaft, bearings, and cast steel impeller. Simple engine throttle adjustments allow changes to pump flow and head performance.

Features

- Rugged construction of cast iron pumpend with cast chromium steel impeller.
- Flow rates to 3500 gpm and heads to 185'.
- Unique double mechanical seal immersed in isolated oil bath for unlimited dry running capability.
- Integral 175 gallon fuel tank capacity provides over 24 hours of continuous operation.
- Safety shutdown system incorporated into engine controls prevents equipment damage from engine fault or failure.
- Impeller designed for general pumping with solids up to 3-1/8" in diameter.
- "Quick-Disconnect" hydraulic fittings simplify setup, installation, and shutdown.
- Standard John Deere 6068T engine — other models including electric drive versions available.

Heidra 250 Performance Curve

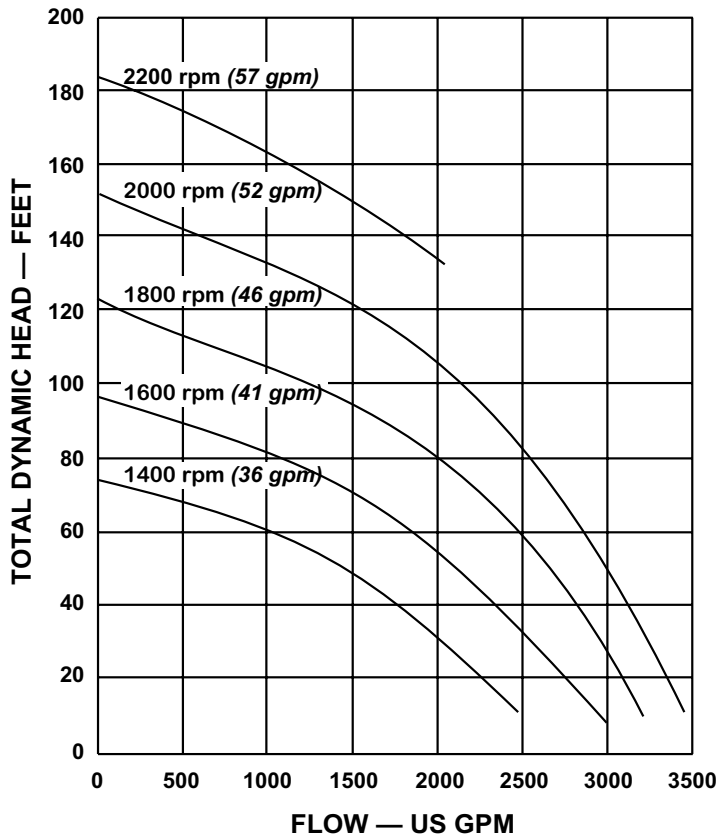

Notes:

- 1 Impeller diameter: 11-2/5" (290 mm)
2. Performance curves based on diesel engine speed
3. Requires hydraulic system pressure to 4000 psi

Performance data based on water testing at sea level and 68° F. Larger diameter pipes may be required for maximum flows.

Dimensions

Heidra 250 — John Deere 6068T, Skid Base
 Pump Weight: 800 lbs.

Complete pumpset is supplied with one each of 1-1/4" X 50' high pressure feed and return hoses and one 1/2" X 50' low pressure case drain hose.

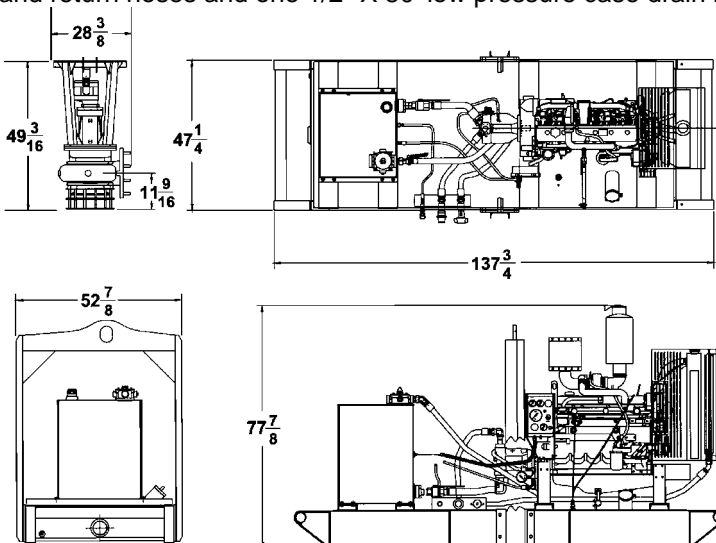

All dimensions listed in inches.

Specifications

Submersible Pump:

- Hydraulic Motor: Fixed Piston
- Drive Pressure: Up to 4000 psi
- Hydraulic Flow: Up to 57 gpm
- Hydraulic Line Length: 100 feet (longer runs with larger hose)
- Solids Handling: Up to 3-1/8" diameter
- Pump Speed: Up to 2200 rpm
- Impeller Diameter: 11-3/7"
- Discharge Flange: 10" ASA 150
- Hydraulic Connections: 1-1/4" Quick Disconnect
- Strainer: Nylon coated with 2-3/4" apertures

Hydraulic Power Pack:

- Engine
 - Horsepower: 147 hp @ 2200 rpm
 - Fuel Consumption: 7.2 gph
 - Fuel Tank Capacity: 175 gallons
- Output
 - Hydraulic Flow: 57 gpm
 - Pressure: 4000 psi
 - Control: From engine speed and pressure compensated
- Hydraulic System: Two pipe, open circuit
- Reservoir: 80 gallon
- Control Valve: Pressure compensated on/off valve
- Connections: 1-1/4" Quick Disconnect feed and return
 1/2" Quick Disconnect case drain
- Filters
 - Supply Line: 125 micron, pleated gauze
 - Return Line: 20 micron



One Floodgate Road, Bridgeport, NJ 08014
 Tel: (856) 467-3636 • Fax: (856) 467-4841
 www.godwinpumps.com

BRANCH LOCATIONS:

- Norwich, CT • Buffalo, NY • Chicago, IL
- Washington, DC • Richmond, VA • Virginia Beach, VA
- Charleston, WV • N. Charleston, SC
- Atlanta, GA • Houston, TX • Raleigh, NC

Specifications and illustrations are subject to revision without notice.
 © Copyright 2000 Godwin Pumps of America, Inc.